



HAND BUILT ELECTRONIC PERCUSSION

2a TWYGCROSS STREET
LEICESTER
LE2 0DU
ENGLAND
TELEPHONE: 0116-255 6225
E-MAIL: info@wernick.net
WEB-SITE: www.wernick.net
VAT No. 834748304

XYLOSYNTH[®]

XS6 -4

Software Version 2.16

Player's Manual

Index

	Page Number
1.0 Introduction	3
1.1 Sound sources and Amplification	
1.2 Setting Up your Xylosynth System	4
1.3 A Quick MIDI Lesson	5
2.0 Pedal Controls	6
2.1 Program +1 and –1 Pedal	
2.2 Transpose Pedal	
2.3 Sustain Pedal	
2.4 Dampening Pedal	7
3.0 Selecting Song List, Incremental Program & Channel Modes & Editing Song List	
3.1 Song List Control	
3.2 Incremental Program Control Change	
3.3 Incremental Channel Number Control	8
3.4 Editing Song List	
4.0 Analogue Settings	9
4.1 Length of Note	
4.2 Sensitivity	
5.0 Re-varnishing and General care of the Keys	10
6.0 How to Replace a Key	
7.0 Physical Specifications	11
8.0 Help	
9.0 How to Contact us	11

1.0 Introduction

Thank you for choosing a Wernick Xylosynth. You are now the owner of a hand built MIDI compatible tuned percussion controller that's designed to put mallet players in the most comfortable MIDI environment possible. We've asked players like you a lot of questions over the last few years and the information we've gathered together has resulted in many of the unique features of the Xylosynth. Innovations like the wooden playing surface on the Wernick Percussion System keys and the flexible, easy to use software have come from this process. We're proud to be a 'musician led' instrument company and continue to strive to realise the imagination of music makers.

While many of you will be MIDI literate and will understand the various intricacies of velocities and note numbers, others will not be so experienced. Please don't be put off though if this is the case as MIDI driven music can foster creativity never before explored through conventional instruments. We've tried to make this manual as easy to follow as possible so please bear with us in the obvious parts and feel free to call or e-mail if you have any trouble with anything.

First things first and what you'll want to know immediately is what you've got for your money. Your basic Xylosynth package should include the following:

- 1 Four Octave Xylosynth**
- 1 Power Supply Adapter**
- 1 Four Metre MIDI (5 Pin DIN) Connector**
- 1 Manual**
- 1 Pair of Soft Marimba Mallets**

1.1 Sound Sources and Amplification

The Xylosynth is a MIDI controller and has no built in sounds. In order to play the Xylosynth you will need several other pieces of related equipment.

The first thing needed is a sound source. This could be a sound module, sampler or even a sound card in your PC or Mac. This, as the name implies, provides the sound. Sound modules with tuned percussion sounds are available from most of the large hi-tech musical equipment manufacturers as well as ourselves. Looking further than the traditional tuned percussion sounds, sound modules also often contain several digital sounds with a very fast attack making them mallet friendly. For the individual sound of your choice you need a sampler. Many Sample CD's with tuned percussion sounds already exist and a sampler also allows you to sample your own unique sounds and play the results on the Xylosynth.

The final link in the chain from Xylosynth to performance is amplification. The simplest thing to do is to plug a pair of good quality headphones into your sound source. For home or studio use a pair of good quality near field monitors in conjunction with an amplifier should work with most sounds. For live performance monitoring a small keyboard or acoustic guitar combo amplifier can give a good mono response. In this case you would use the house PA. To really appreciate the stereo of most of the sounds you'll be using the best solution is a small mixer, a power amp and a pair of medium size speakers (ideally 12" Drivers) or active speakers can be a very simple option. As with all amplification it's important to tailor your system to every possible requirement you can think of. We do advise you should try out the amplification system before you buy or find very good recommendations.

1.2 Setting Up your Xylosynth System

After a bit of practice setting up a Xylosynth system should only take a couple of minutes. Always make sure you mount your Xylosynth on a solid table or keyboard stand.

1. Make sure flight case is the right way up (the lid has the handles), undo butterfly catches & lift off the lid. **Note: the end pieces of the Xylosynth are at the wheel end of the flight case for packing away. Damage may be caused to the Xylosynth hinges if packed the other way around**
2. Lift the Instrument & carry slowly to a suitable place which is level.
3. Accessories can now be retrieved from the base of the case & if setting up the Instrument you will first need the hand tools as well as 2 Chrome Plates that should be under the long sustain pedal.
4. You can set up on a fine carpet if the carpet is clean (so as not to scratch the wooden bars when resting on the carpet). If the floor does not have a suitable carpet then use cloth 160cm x 30cm (63" x 12") minimum. Place the Instrument with its Bars or Keys resting down on the protected floor. It does not matter which side but for ease longest section face down.

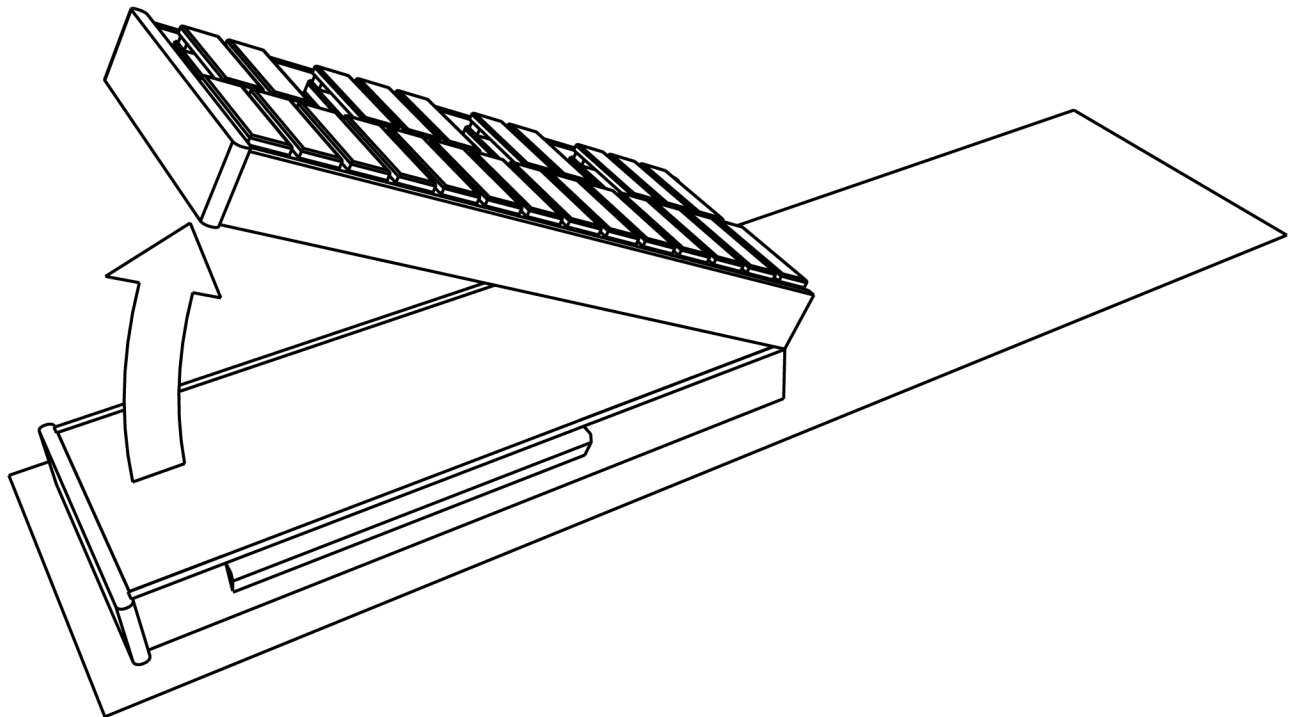

5. Now unfold the Instrument slowly & for your safety keep away from the Hinge area. Make sure nothing gets caught around this area eg. Cloth or carpet hairs by inspection. The Instrument should be left in this upside down position until the Chrome plates are fixed in place with the supplied hand tools. Loosen the 8 bolts clearly visible by warning instructions & slide a chrome plate under the heads of 4 of these bolts. Tighten these bolts making sure the chrome plate is as close against the side of the Instrument as possible.
6. Now repeat for the other Chrome plate on the other side.
7. Now carefully turn over the Instrument if you have help. If you are on your own the Instrument can be lifted up on one end.

8. Care must be taken if placing the Instrument on a table top as the hinges now underneath the Instrument can scratch the table surface. So to avoid this lower the instrument slowly and horizontally onto the table.

Reverse these Instructions to break down and pack away the Instrument.

Once the Instrument is positioned safely, you may connect the instrument. If you look to the right hand side of the front panel you'll see the connections for Power In, MIDI Out, Blue LED indicator, Dampening Pedal, Sustain Pedal, Transpose Pedal and the two Program Change foot pedals.

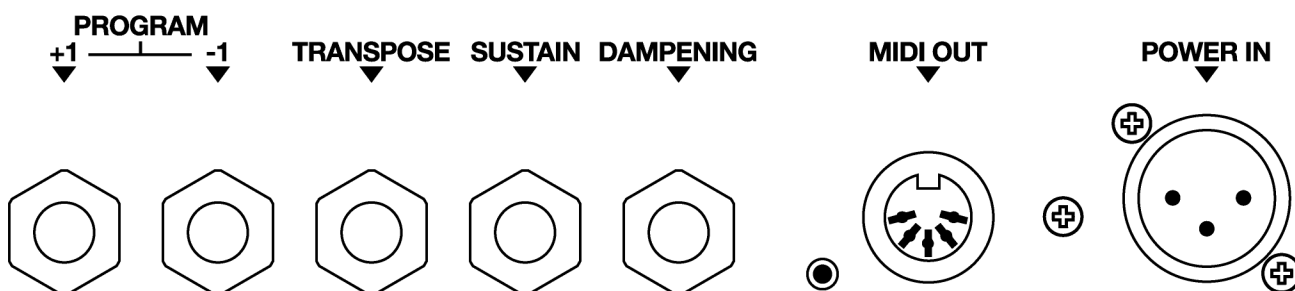

Plug the power supply unit into a wall socket & the XLR connector into the instrument (power in). There is no on/off switch but the blue LED should flash during power up. Then, using the supplied MIDI lead, connect the MIDI Out socket on the Xylosynth to the MIDI In socket on your sound source.

1.3 A Quick MIDI Lesson

Before we go on to setting up the Xylosynth it might be useful if you are completely in the dark about MIDI to include a short section on the basics. You don't have to be a rocket scientist but a little knowledge will make things easier.

MIDI stands for Musical Instrument Digital Interface and is a digital computer code that all manufacturers in the music industry use. It means that the Xylosynth and any other MIDI device can 'talk to each other'. It's become a world wide standard so you will be able to find MIDI equipment that's compatible with the Xylosynth everywhere. We could go on for pages but there are many volumes dedicated to the subject and to be honest all you really need to understand to use your Xylosynth are the following four parameters:

MIDI Channel Number

There are 16 Channels in MIDI and these are the codes used to allow different MIDI devices to talk to each other. This Xylosynth uses the first channel.

MIDI Program Number

The Program Number is the code number for the sound that comes from the sound source you're using and there are 128. Normally the sound source will have a name for each sound displayed on its screen. Some sound sources have several banks of sounds with 128 different sounds in each.

MIDI Note Number

There are 128 Note Numbers in MIDI and these define the pitch of any sound you have accessed. If you like it's like having a keyboard with 128 keys. Generally a four octave

Xylosynth configured C to C starts at MIDI Note Number 36 and goes to MIDI Note Number 84. An easy reference point to remember is Middle C (C3) which is MIDI Note Number 60.

MIDI Velocity Number

There are 128 levels of velocity in MIDI. The Velocity Number defines the amount of expression that can be applied to a MIDI sound. For example if you play a Vibe bar really hard the sound is very loud compared to if you give it a gentle stroke. Basically the same thing applies in MIDI and is defined within 128 levels from 1 to 128. A level of 0 is equivalent to a note off message. Of course with the Xylosynth you do not need to hit the keys really hard to achieve maximum velocity or sound.

2.0 Pedal Controls

Using a pedal with $\frac{1}{4}$ " Jack and plugging into the pedal inputs at the front of the Xylosynth can access many controls using your feet. The pedal must be 'normally open' logic ie. open circuit and when pressing the pedal making a closed circuit or short. Some pedals will have a switch on the back to change the logic from normally closed to normally open. The Xylosynth will not work with the wrong logic pedal and **Note: Do not plug anything other than non-powered pedals. You will damage a chip inside that will have to be replaced if you plug a signal output jack or other device that is carrying a Voltage.**

2.1 Program +1 and -1 Pedal

Pedal inputs +1 and -1 can be considered as up or down or moving forwards or backwards in a sequence. There are three modes of control that these pedals can control in a live situation or just editing. These modes are described in further detail in section 3.

2.2 Transpose Pedal

Pedal input 'Transpose' will change the range of the keyboard layout. On start up the instrument's range is from C2-C5 for C-C Xylosynth or F2-F5 for F-F Xylosynth. By pressing the pedal and striking a key you are setting C3 (middle C) or F3 respectively. This means you can have a Midi range from C0-C6 or F0-F6. This happens in 'real time' so that notes from the previous setting are allowed to play on even though you are in the process of setting or are actually in a new range.

However this Transpose can be redundant with newer or more expensive sound sources as you can program them in different octave ranges for different programs and use the 'Program+1' and 'Program-1' pedal inputs to change the octave ranges.

As you can strike any key to set where C3 or F3 is you can transpose lets say a third or fifth etc.

2.3 Sustain Pedal

Pedal Input 'Sustain' will sustain all notes playing when you press the pedal. When you release the pedal all the notes will switch off. The sound you are playing will have to sustain or be looped for the sustain pedal to be effective. For example Vibes sound will

sustain but not Marimba. And if you are fast with using this pedal you can play monophonic pieces by quickly releasing the sustain pedal after each note.

2.4 Dampening Pedal

Pedal Input 'Dampening' will switch off individual notes if the pedal is pressed and individual notes are hit. This pedal can not be used in conjunction with the sustain pedal. Dampening can also be achieved by striking a note gently a second time (there is a technique to this).

3.0 Selecting Song List, Incremental Program and Channel Modes and Editing Song List.

In this section we are able to change modes for the Program +1 and -1 inputs and edit the Song List. Importantly the Xylosynth will send you to the beginning of the sequence when selecting or re-selecting a mode but under normal power down and power up the Xylosynth will remember which mode and where you were in the sequence. And even though you may use all the pedal inputs to edit and set the Xylosynth you only need to use one pedal and simply plug/unplug them in the correct order. We ask you to press the pedal input (and tell you which pedal input) on power up. To do this you first need to unplug the power lead. Then plug the Jack of the Pedal into the correct Pedal input. Then hold down or press the Pedal. Then **wait a good few seconds** to ensure the instrument has completely powered down before plugging in the mains plug or XLR to the Xylosynth. The Blue light should light up momentarily on the front of the Xylosynth and as soon as the blue light disappears you can release the Pedal. If the blue light stays on then you didn't allow the instrument to fully power down. Power down again and repeat the process ensuring enough time has elapsed.

3.1 Song List Control

Pedal inputs 'Program +1 and -1' will change the next or previous Program Number in the Song List sequence. When the Xylosynth is powered up for the first time the Song List is the default mode and there is a simple Song List that gives Glockenspeil, Vibraphone, Xylophone and Marimba in General Midi (GM) when pressing the pedal inputs Program +1 or -1. If you were in another Mode (Incremental Program or Channel Number as described below) you have to reset the Xylosynth to Song List mode. **To reset to this mode press the pedal input 'Transpose' on power up.**

Changing Program Number happens in 'real time' so notes from the previous program are allowed to play on even though you are in a new program. If you reach the end of the sequence and go up it will cycle you to the start of the sequence or if at the beginning of the sequence and you go down 1 you will cycle to the end of the sequence. There is a maximum of 50 programs in a Song List. Individual sound sources vary so if you accidentally change program and you have unwanted ringing notes you can twist the length of note knob as a panic button as this sends an 'all notes off' message of this particular channel. However some soft samplers and sequencers do not act on an 'all notes off' message.

3.2 Incremental Program Control Change

Pedal inputs 'Program +1 and -1' will send a control change increment or decrement (control 96 or 97) message. **To set to this mode press the pedal input 'Sustain' on power up.** This function happens in 'real time' so notes from the previous program are allowed to play on even though you are in a new program. Some sound modules will not

recognize this function or will need to be programmed. But this function is useful for some software programs as there is no limitation like 'program number' which is limited to 128. Individual sound sources vary so if you accidentally change program and you have unwanted ringing notes you can twist the length of note knob as a panic button as this sends an 'all notes off' message of this particular channel.

3.3 Incremental Channel Number Control

Pedal inputs 'Program +1 and -1' will change the Channel Number in the sound source up by one or down by one. You have to set the Xylosynth to this mode but the Xylosynth will remember which mode and Channel number you were in before power down. **To set in this mode press the pedal input 'Dampening' on power up.** This will also set you to the beginning of the sequence (in this mode is Channel 1).

Generally you will just want to set the Xylosynth to a particular Channel number and then leave for sometime. We would then suggest that after setting (by pressing the Program +or -1 Pedal inputs) you then change the mode to Song List or incremental Program Number so the Channel Number cannot be changed accidentally. The Incremental Channel Number Control works similar to the Incremental Program Number Control. Changing Channel happens in 'real time' so notes from the previous Channel are allowed to play on even though you are in a new Channel. If you reach 16 and go up it will cycle you to the start at 1 or if at 1 and you go down 1 you will cycle to the top at 16. Care must be taken as Individual sound sources vary so if you accidentally change Channel and you have unwanted ringing notes you may have to hit the panic button on the sound source. Using the Length of Note knob as a panic button will have no effect unless you are in the correct channel.

3.4 Editing Song List

Song List editing is very easy if you have the sound module plugged into the Xylosynth so do this first. You should also have the sound module display in view and have the song list preferably written down to follow. Make sure no one is going to hit the keys as you will be using them to select the Program Numbers. Now you are ready to edit and follow these instructions:

Press the pedal input 'Program +1' on power up. You are now in Edit mode.

Strike a white key about an octave down from the top key and you should see a new program number displayed on the sound module. It should read either 60,70 or 80. Hit the key quite hard if it did not show on the sound module (in edit mode the keys are not working so quickly). If it showed 59,69 or 79 then we need to change the logic (some sound sources work on Program Numbers 0-127 and some 1-128). To change the logic simply press the pedal input 'Program -1' on power up. Then press the pedal input 'Program +1' on power up to get back into Edit mode.

To select the first number in your song list lets say program number 125 you will have to strike a white key to get 120 and a black key to get the 5 to make 125. There are 13 white keys in the top two octaves that will give you the decades (0,10,20,30,.....120) and all the black keys that will give the digits (0,1,2,3,....9). You can find the white key that gives 120 by either trial and error or by counting up from the start of the second octave **but do not hit the top white key as you will exit the Edit mode.** You should be able to see the numbers on the sound module display and do not worry if you make a mistake as nothing is saved until you want to save (unless you exit the edit mode).

Once you have the correct program number displayed on the sound source you can then save by simply pressing the Program +1 pedal and releasing. The Xylosynth is now waiting for the second in the Song List. (You could exit here by either hitting the top white key or unplugging the Xylosynth but you would only have a song list of one program). Lets say you wanted program 6. You could achieve this by just hitting a black key as before corresponding to Program 6 or hit a White Key corresponding to 00 and a Black Key

corresponding to 6. You can hit White Keys followed by Black Keys or the other way around. Once you see the correctly displayed Program number then press the Program +1 pedal to save this.

Carry on doing these operations until you have built up your song list. Once you have the last Program number of your song list displayed press the Program +1 pedal for the last

time. Then hit the top white key and you will see Program 0 displayed. You have now exited the Edit mode and you are now in Song List mode where you can play normally. Hit a few keys to test and then test the song list by simply pressing the Program +1 pedal. It should correctly flick through the Song List and will be remembered until you go back into this Edit mode.

4.0 Analogue Settings

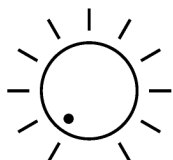

SENSITIVITY

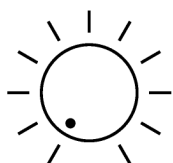

NOTE LENGTH

4.1 Length of Note

Often called Gate Time, Note Length control enables each individual note to be precisely controlled allowing you to exactly define your sound. The control begins with Instant Note Off at 0.03 seconds (30 Milliseconds) and goes up to 8 seconds. Really tight control is available on the very short times where it's needed most with increments of 0.080 seconds (80 Milliseconds) up to 0.4 seconds and then less control over the long lengths used more commonly for sampled sounds. The Length of Note is set by the analogue knob on the right on the upper right of the playing surface. If you adjust the knob when notes are still playing these will be individually switched off and an 'all notes off' message is also sent so it can be used as a 'panic button'. Only when you stop adjusting the knob will notes be played normally.

4.2 Sensitivity

This is the master sensitivity control and affects all the keys equally and no matter which Patch you are in. It can be used to adapt the Xylosynth's playing characteristics exactly to your style. Sensitivity is set by the analogue knob on the upper right of the playing surface. Turning the sensitivity knob to its lowest setting will make the hardest hits of the Keys only achieve about 25% Midi velocity. Increase about a half of a turn and hard Key hits will produce maximum Midi velocity. So in effect the sensitivity control can act as a volume control knob.

For the second half of the adjustment that gives the full 127 note velocity values you can adjust to your playing characteristics/mallets you use. Start with the sensitivity knob set to its maximum setting and then when striking a Key to the hardest you are likely to play, turn the knob anticlockwise. When the sound heard starts to drop from your sound source stop turning the sensitivity knob. Or otherwise just set the knob to halfway and get used to this

dynamic range. We strongly advise you use soft Marimba mallets to give a good range and keeping the acoustic contact sound minimal. These mallets will also protect the sensors. Note that whatever setting of the sensitivity knob, the lightest of Key hits and corresponding low Midi velocity numbers will not be affected.

5.0 Re-varnishing and General Care of the Keys

You may at some point in the future feel it necessary to re-varnish the keys. For the dark wood Bubinga keys this can be done using **Rustins Danish Oil**. With a clean cloth dipped sparingly in the oil wipe over the keys and leave to dry overnight. If there are scratches you want to get rid of then you can lightly sand the keys with very fine sandpaper first and then oil them. It is strongly advisable not to subject the keys to sudden changes in temperature including keeping them out of direct sunlight. For example if you have to leave your instrument in a large auditorium over night we strongly advise you insulate the keys by placing a thick padded cover over them (maybe a soft bag you have for the instrument) or putting the whole instrument into a flight case. Never leave next to a radiator. Cleaning between the keys can be done using plastic tubing 10mm external diameter attached with gaffa tape to the hose of a vacuum cleaner.

6.0 How to Replace a Key

Tools Required

'Pozi Drive' Screwdriver. Bit size PZD1 & referred to as cross head and a 7mm socket or spanner for M4 nuts.

General Notes

Replacing a Key should take less than 20 minutes if you have carried out this operation before. This time can be reduced if you use a Pozi (PZD1) bit with a battery operated drill to remove & fix screws that hold the Bottom Panels. But only use a battery operated drill if you are proficient with using one. Make sure not to over tighten the screws that hold the bottom cover and this means carrying out the **final tightening of the screws by hand** if necessary. If using a battery powered drill you will have to stop before the screws 'bottom out' i.e. slowing down well before then. Hand tightening means just 'nipping up' the screws. Also try not to touch any of the board components as all the electronics are static sensitive.

Description

1/ Find a suitable area to carry out the task. You can set up on a fine carpet if the carpet is clean (so as not to scratch the wooden bars when resting on the carpet). If the floor does not have a suitable carpet then use cloth 120cm x 30cm (48" x 12") minimum. Or you can work on a table top with a table cloth.

2/ Now place the Xylosynth upside down onto the work area.

3/ Undo & remove, with the battery powered drill if you if you are able to, all cross head screws securing the bottom panel. Then lift off the panel.

4/ Locate the key to be replaced. Gently pull off the white plastic housing after releasing the springy plastic clip holding it in place. Now undo & remove the two nuts and crinkle washers.

5/ To remove the Key you will need to do two operations at once. Get your hand under the Key to be removed & work the Key out with your other hand. You may find this operation easier to do if you are able to raise the instrument onto its front or back edge.

You may need to coax the connector housing through the hole. Take care not to pull the wires unduly.

6/ Re assembly is the opposite process but concern yourself with the points below as well as the general notes at the top. When putting the new Key in be careful not to trap any wires coming from the Key. Compare the wire loop with keys nearby as they should all be the same. Also you can test this before putting the crinkle washers & nuts by moving the wires into & out of the hole noticing that they are free to move. If not tease the wires so that they become free. Now place and tighten up the nuts so the crinkle washers grip into the circuit board and Aluminium but do not over tighten to completely flatten the crinkle washers.. Clean with tissue or cloth the two gold plated pins of the connector block to remove any grease/oil that may have come from your fingers prior to pushing the the key connector housing back onto the block. The housing only fits on one way. Place the bottom cover back on the same way round as it came off and place and tighten a couple of screws in the Holes. Carefully tighten the screws. Then turn the Xylosynth the correct way up and test the key to see if it working properly. You can just look at the Blue LED and tap the key when the power lead is plugged in. If OK then put the remaining scews into the bottom cover.

7.0 Physical Specifications

	4 Octave
Overall Length:	1600mm (63") Folded 865mm (34")
Height:	82mm (3.5")
Depth:	360mm (14")
Weight:	16.4 Kg (36lb)
Keys:	49

8.0 Help

We are a small and friendly electronic percussion company and we will help in any way we can with any queries. You are never more than a phone call or e-mail away from expert advice and in our experience 99% of problems can be solved this way. If something more urgent happens we can help you assess the problem and find the best way forward as quickly as possible. As well as this we are happy to give advice on other related equipment and keep our web-page up to date with new developments so you'll always know what's new with Wernick.

9.0 How to Contact Us

Telephone:	+44 (0) 116-255-6225
e-mail:	info@wernick.net
URL:	http://www.wernick.net
Contact Name:	Will Wernick, Julie-Ellen John
Patents:	United States 5854436 UK & France (EP) 0732683 Germany 69610518

© Wernick Musical Instruments 2006 All Rights Reserved.
All Specifications in this manual are subject to change without notification